

137,037

PATENT



SPECIFICATION

Convention Date (France), Dec. 21, 1918.

Application Date (in United Kingdom), Dec. 3, 1919. No. 30,229/19.

Complete Accepted, June 3, 1920.

COMPLETE SPECIFICATION.

An Improved Motor Car Propelled by an Air Screw Propeller.

I, MARCEL LEYAT, of No. 27, Quai de Grenelle, Paris, France, Engineer, do hereby declare the nature of this invention and in what manner the same is to be performed, to be particularly described and ascertained in and by the following statement:—

5 This invention relates to motor cars propelled by an air screw propeller.

It has already been proposed to build vehicles propelled by air screw propellers situated either in front or at the rear of the vehicle.

10 In their general construction the said vehicles are not appreciably different from ordinary vehicles in which the engine drives the wheels; in so far as they comprise front wheels for directional purposes, fixed rear wheels which are provided with brakes and on which a car body is mounted having stream lines so as to reduce the resistance to forward progress. In other vehicles of the same kind the framework constitutes the car body, but it is so constructed that it is not possible to obtain a great rigidity and at the same time a great light-
15 ness, which conditions are indispensable for high speeds.

The present invention has for its object to provide a vehicle propelled by an air screw propeller, all the elements of which have been combined together in such a manner as to produce the simplest and most economical constructions possible, whilst assuring a very high degree of stability and strength as
20 well as remarkable ease and safety in the running of the vehicle.

The improved motor car is characterised in that it consists of a car body constituting the chassis composed of a trussed girder covered with a suitable covering; this girder is supported at its front end on non-swivelling wheels fitted with the necessary brakes, and at its rear end on a steering wheel or
25 a steering wheeled axle. The engine with the power-transmitting mechanism is situated preferably at the front end of the car body-chassis, and drives a tractor screw propeller situated in front of the car body and surrounded with a protector.

The trussed girder constituting the car body-chassis is made sufficiently
30 strong to carry the weight of the driver and passengers and the machinery, and thus allows of dispensing with the separate chassis usually employed in motor-cars, thus combining great lightness and great rigidity with a very simple and very economical construction. The arrangement of a non-swivelling front wheeled axle allows likewise of simplifying the construction; it also
35 affords a very high degree of safety since the said wheeled axle which is subjected to jolts has no share in the steering of the car, which latter being

[Price 1/-]

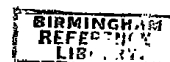

arranged at the rear, is also protected as effectively as possible against all accident. Finally this arrangement is very adaptable to the use of brakes upon the front wheels and allows of gaining all the advantages of such brakes without entailing the drawbacks that are incurred when it is a case of braking swivelling wheels. 5

The motor apparatus driving the screw propeller is situated preferably in the front part of the trussed girder; it comprises with the engine and its accessories all the parts for operating the screw propeller, namely, the mechanism for starting, reversing, braking, locking and unlocking the screw propeller, *etc.*, and in the case of a reversible screw propeller, the mechanism for varying the angle of the blades of the propeller. The grouping of the whole of the mechanical part at the front, affords the advantages of great lightness and economy in construction, a considerable ease of maintenance and control, and also safety for the passengers in the case of collision and a higher efficiency of the propeller which, being surrounded by its protector, is in full view of the driver and the passers by. 10 15

A constructional form of the subject matter of this invention is illustrated in the accompanying drawings in which:—

Fig. 1 is a side elevation,

Fig. 2 is a plan, and

Fig. 3 is a front end view of the improved car. 20

Fig. 4 is a rear end view partly in section, of a modification in which the rear steering wheel is replaced by a steering axle with two steering wheels.

Fig. 5 is a plan corresponding to Fig. 4.

a is the car body-chassis composed of frames *a*¹ of wood, steel, aluminium, *etc.*, upon which is applied a suitable covering of ply-wood, steel or aluminium, *etc.*, sheeting, canvas or other material. 25

This car body has preferably a streamline shape so as to offer the minimum resistance to forward progress; it contains the requisite entrances, openings and seats. 30

It rests at its front end through the medium of leaf springs *b* on an axle *b*¹ provided with wheels *b*². These wheels are provided with brakes *b*³ operated by a brake pedal *b*⁴ through the medium of a transmission *b*⁵.

The rear steering wheel *c* is mounted in a fork *c*¹ with pivot pin *c*² that supports the car body through the medium of a shock absorber *c*³. A cable transmission *c*⁴ operated by a hand steering wheel *c*⁵, allows of swivelling the wheel *c* in every direction owing to the form adopted for the rear part of the car body. 35

In the modification shown in Figs. 4 and 5, the single steering wheel is replaced by two steering wheels *d* mounted on an axle *d*¹ connected to the pivot pin *d*² by a leaf spring *d*³. Cables *d*⁴ of the transmission act directly upon the axle. In this case it is preferred to give to the rear wheels a track smaller than that of the front wheels in order to diminish the width of the rear end of the car. 40

The motor apparatus situated in the front, consists of the engine *e*, the mechanism *e*¹ for throwing the engine into and out of gear and changing the speed, and the screw propeller *f*. The latter revolves inside a circular protector *f*¹ connected to the car body by brackets *f*². 45

Having now particularly described and ascertained the nature of my said invention and in what manner the same is to be performed, I declare that what I claim is:— 50

1. A motor car propelled by an air screw propeller, characterised by the feature that it consists of a car body, constituting the chassis, composed of a trussed girder covered with a suitable covering; the said car body-chassis resting in front upon non-swivelling wheels provided with brakes, and at its rear end upon one or more steering wheels, and comprising preferably in its 55

front part the motor apparatus driving a tractor air screw propeller surrounded by a protector.

2. An improved motor car propelled by an air screw propeller, constructed substantially as hereinbefore described and also as illustrated in and by the
5 accompanying drawings..

Dated this 2nd day of December, 1919.

MARKS & CLERK.

Redhill: Printed for His Majesty's Stationery Office, by Love & Malcomson, Ltd.—1920.

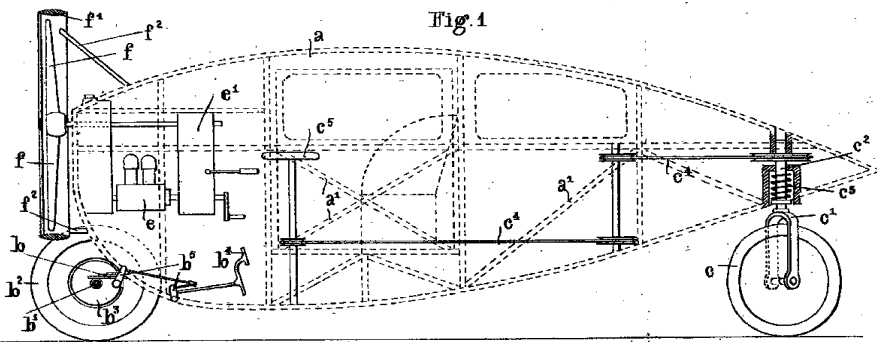

Fig. 1

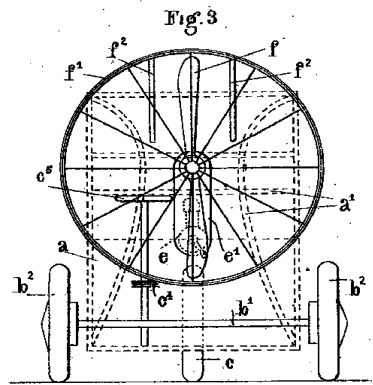

Fig. 3

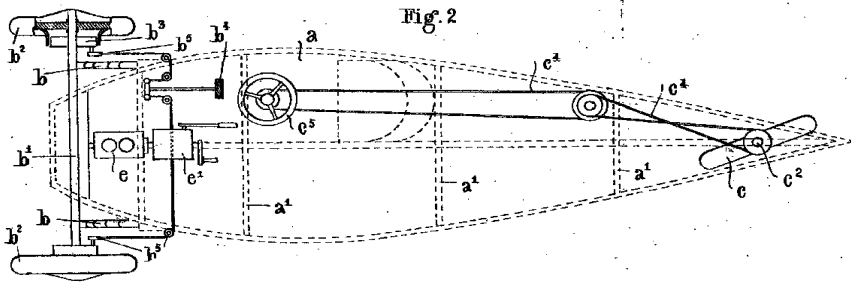

Fig. 2

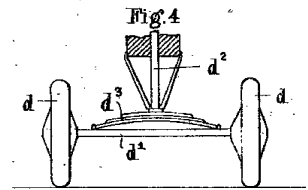

Fig. 4

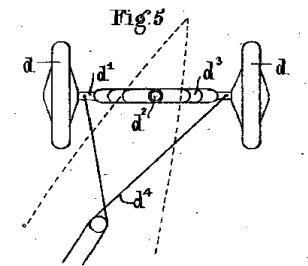
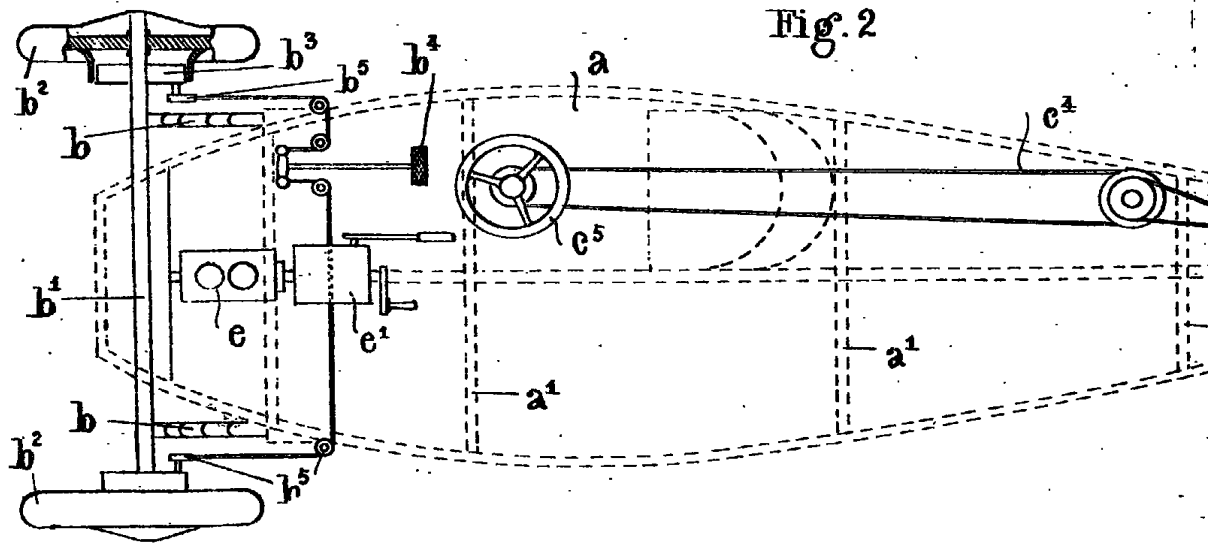
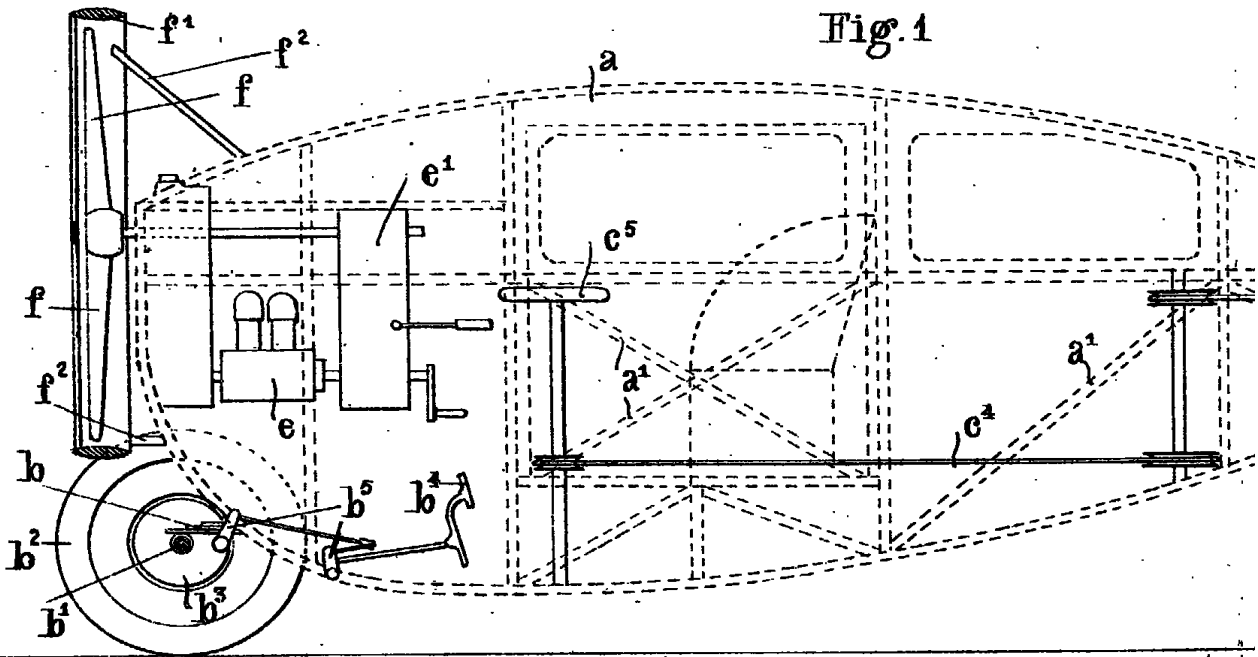

Fig. 5

[This Drawing is a reproduction of the Original on a reduced scale.]

[This Drawing is a reproduction of the Original on a reduced scale.]



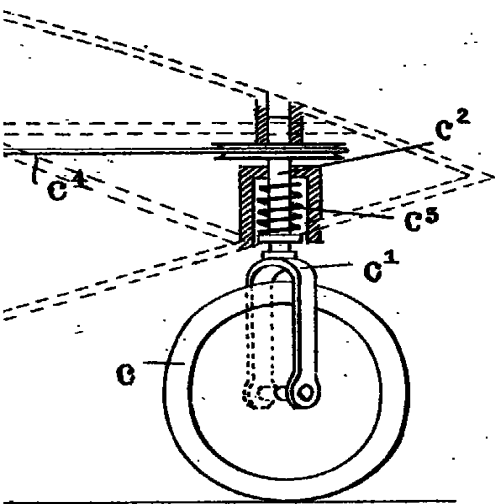

Fig. 3

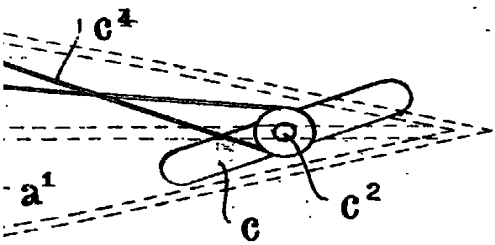
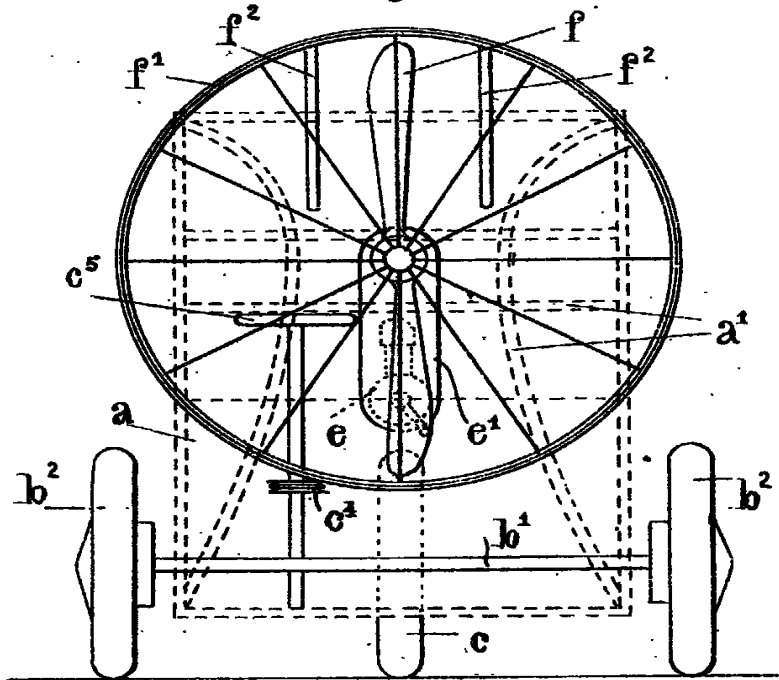

Fig. 4

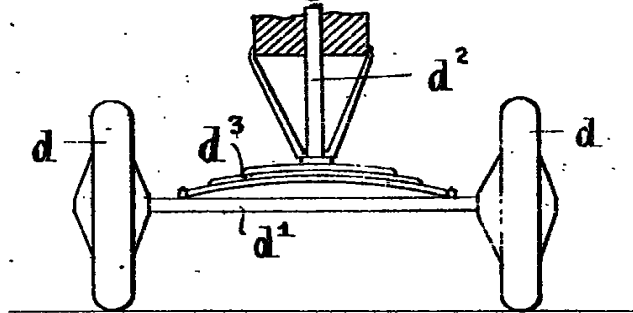

Fig. 5

